

HOBART701 S Ridge Avenue, Troy, OH 45374
1-888-4HOBART • www.hobartcorp.com**HS7N-HV
SLICER****HOBART****STANDARD FEATURES****KNIFE**

- 13" CleanCut™ Knife
- Removable Ring Guard Cover
- Zero Knife Exposure
- Heavy-Gauge Stainless Steel Knife Cover
- Top-Mounted Borazon Stone Sharpener

OPERATION

- ½ H.P. Knife Drive Motor
- Timing Belt for Automatic Drive System
- Variable Four-Speed Automatic Carriage with Front Mounted Controls
- Three Stroke Lengths

INTERLOCKS

- Home-Start Position
- No-Volt Release

HOUSING AND BASE

- Burnished Aluminum Base
- Machine Grooves on Gauge Plate and Knife Cover
- Exclusive Tilting, Removable Carriage System
- Electroless Nickel Plated Single Slide Rod with Reservoir Wick in Transport
- Double-Action Indexing Cam
- Manual Lift Handle
- Ergonomic-Style Handle
- Rear-Mounted, Removable Meat/Vegetable Grip Arm

ACCESSORIES

- Full Fence
- Food Chute
- Debris Deflector

MODELS

- HS7N-HV50C – Automatic Slicer/Burnished Finish with Non-Removable Knife Feature, 220-240 volts, 50 Hz with 240 volt power cord & no plug
- HS7N-HV60C – Automatic Slicer/Burnished Finish with Non-Removable Knife Feature, 220-240 volts, 60 Hz with 240 volt power cord & no plug

Specifications, Details and Dimensions on Inside and Back.

**HS7N-HV SLICER**

HS7N-HV SLICER



701 S Ridge Avenue, Troy, OH 45374
1-888-4HOBART • www.hobartcorp.com

SOLUTIONS / BENEFITS

PRECISION SLICING

13" CleanCut™ Knife

- Super alloy edge stays sharp longer
- Lasts two to three times longer than carbon coated or stainless steel knives

Top Mounted Borazon Stone Sharpener

- Single-action sharpens and hones in just five seconds
- Removable and warewasher safe for easy cleaning and sanitation – can be used wet or dry
- Lifetime guaranteed Borazon sharpening stones provide maximum performance with reduced maintenance costs

Machined Grooves on Gauge Plate and Knife Cover

- Reduces drag for smoother slicing motion

Double-Action Indexing Cam

- The first full revolution of the indexing knob provides precise control of shaving, chipping and thin slicing
- The second revolution opens the gauge plate quickly for thicker slicing
- Gauge plate holds position for consistent, precision slicing

EASY TO USE

½ H.P. Knife Drive Motor

- Reserve power runs at 430 rpm for optimum results

Timing Belt Automatic Drive System

- Extends belt life while producing optimum slicing results
- Quieter operating slicer
- Four carriage speeds including 28, 38, 48 and 58 strokes per minute

Three Stroke Lengths

- Three stroke lengths ideal for a variety of products

Electroless Nickel Plated Single Slide Rod with Reservoir Wick in Transport

- Smooth operation with continuous lubrication of carriage rod

Zero Knife Exposure*

- Knife edge is covered when sharpener is both mounted and removed, making cleaning easier
- Gauge plate remains closed during operation of sharpener

Home Start Position

- Carriage must be in 'home position' before the slicer will start

No Volt Release

- Slicer must be restarted if power fails or slicer is unplugged

EASY TO CLEAN

Removable Ring Guard Cover*

- Catches product debris around the knife for easy removal during cleaning
- Reduces time to 'floss' during cleaning

Exclusive Tilting, Removable Carriage System*

- Tilt design allows for ease of mid-day cleaning
- Removable for complete cleaning and sanitation

Rear-Mounted, Removable Meat Grip Arm

- Opens up front of product tray for unobstructed loading
- Removable meat grip allows for easy cleaning

Manual Lift Handle

- Props machine for easy cleaning underneath slicer

Sanitary Burnished Aluminum Base

- Limited cracks/crevices or bolt holes where product can lodge and bacteria may grow
- Easy clean up and durable finish

*Feature unique to Hobart



701 S Ridge Avenue, Troy, OH 45374
1-888-4HOBART • www.hobartcorp.com

HS7N-HV SLICER

SPECIFICATIONS

KNIFE

13" CleanCut Knife: The knife is approximately 13 inches, constructed of 304L stainless steel and high performance Stellite alloy. Knife cover is retained magnetically, and is quickly removed by pulling straight back on the top cover knob.

Removable Ring Guard Cover: Fits on top of ring guard to catch food debris. When removed, reveals a 0.12" space between knife and guard for easier flossing. Ring guard is made with Zytel™ plastic and can be washed in warewasher or three compartment sink.

Zero Knife Exposure: Knife edge is not exposed during cleaning or sharpening procedures.

Top Mounted Borazon Stone Sharpener: Single action operation utilizing two Borazon stones to sharpen and hone in five seconds. Removable, top mounted and warewasher safe. When sharpener is removed for cleaning, knife edge is completely shielded. Borazon stones have a lifetime guarantee.

MOTOR

Poly V-Belt Knife Drive System: Knife is driven by a Hobart Poly V belt and runs at 430 rpm for optimal performance.

Four Stroke Speeds: Stroke speed can be set to 28, 38, 48 and 58 strokes per minute.

½ H.P. Knife Drive Motor: ½ H.P. permanently lubricated ball bearings. Single phase capacitor-start, induction run.

INTERLOCKS

Home Start Position: Home-start ensures carriage is in a convenient position before starting the slicer.

No Volt Release: In the event of a power loss, slicer must be restarted before operation can continue.

HOUSING AND BASE

Sanitary Burnished Aluminum Base: One-piece base has fewer places to harbor soil and is easier to clean. Limits holes or crevices in which food can lodge.

Finish: Stainless steel top cover, anodized aluminum product tray and gauge plate.

Exclusive Tilting, Removable Carriage System: Aluminum product tray tilts easily for mid-day cleaning and is removable for thorough cleaning and sanitation procedures. The carriage has 12.5" manual travel.

Electroless Nickel Plated Single Slide Rod with Reservoir Wick in Transport: Transport slide rod is E-Nickel electroless plated. Slide rod bearings feature an oil reservoir/oil wick.

Double-Action Indexing Cam: A solid construction index knob moves the gauge plate via a barrel cam ensuring consistent slice thickness across machine and over time. First revolution of index cam for precision slicing; second revolution for thicker slicing selection.

Manual Lift Lever: Helps hold slicer in tilted position for cleaning beneath the machine.

Ergonomic Style Handle: Specially shaped and positioned for ease of use during manual operation.

Rear Mounted, Removable Meat Grip Arm: Rear mounted grip is high strength thermoplastic. Swings out of way when not in use.

Electrical Specification: Available in 220-240/50/1; 2.8 Amps and 220-240/60/1; 2.8 Amps - Not submitted for ETL Listing.

Switch: Moisture protected push button switch.

Cord & Plug: 6-foot, three-wire power supply cord (no plug) on the HS7N-HV50C and HS7N-HV60C.

Capacity: The carriage will take food up to 5¾" x 10¾" rectangle or 7.5" in diameter.

Gauge Plate: Gauge plate is a heavy aluminum extrusion with machined grooves for smooth feeding. Adjustable to cut any thickness of slice up to 1".

Warranty: All parts and service coverage for one year including knife. Lifetime guarantee on Borazon stones in the sharpening system. This warranty is valid in the U.S. and Canada. However, warranty may vary in other countries.

Shipping Weight: 138 lbs.

HS7N-HV SLICER

HOBART

701 S Ridge Avenue, Troy, OH 45374
1-888-4HOBART • www.hobartcorp.com

DETAILS AND DIMENSIONS

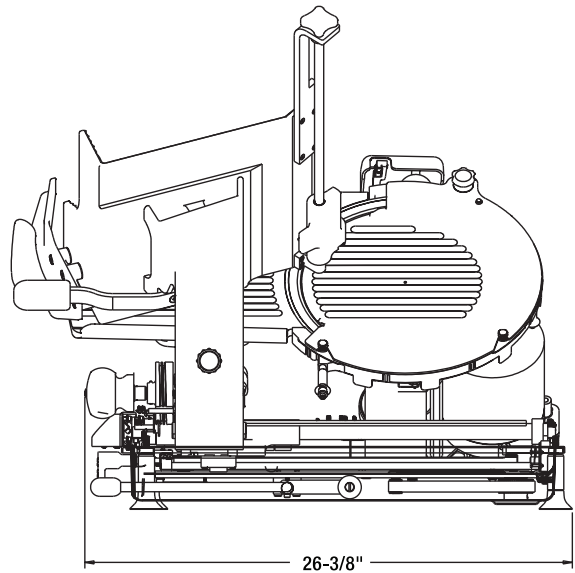
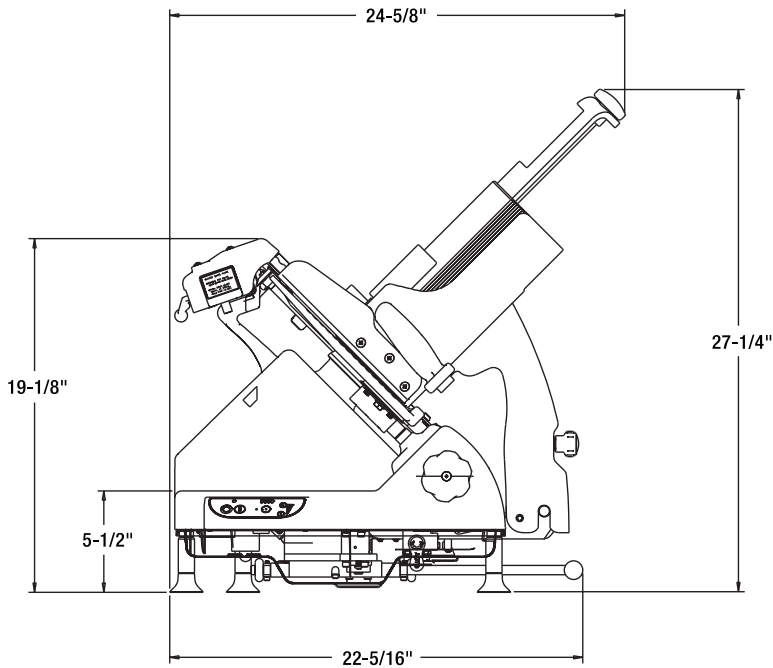
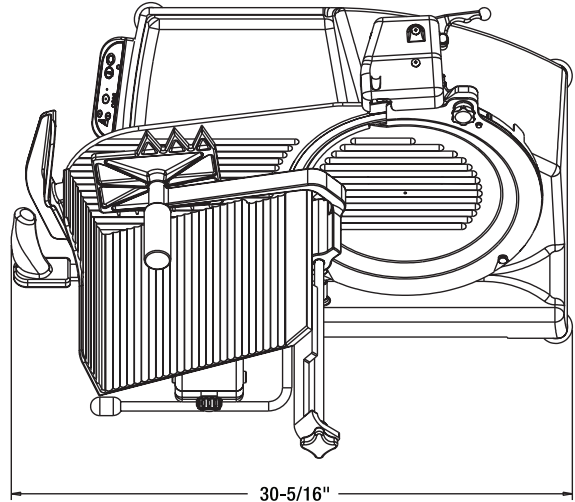

As continued product improvement is a policy of Hobart, specifications are subject to change without notice.