

SCOTSMAN

MODULAR ICE STORAGE BINS

BH900

VOLUME STORAGE – AMPLE ICE RESERVE

- Holds up to 740 lbs. per ARI standard 820-95.
- Horizontal design—low profile, fits where ceilings are low.
- Accepts one or more Modular Cubers, Flakers or Nugget Ice Makers.

QUALITY CONSTRUCTION

- Stainless steel construction.
- NSF approved construction.
- Polyethylene Bin Interior.

WARRANTY PROTECTION *See Dealer for complete warranty details.*

- 3 years parts and labor on all components.
- Directory of Certified Dealer Service.



Bin includes 6" black enamel legs w/ adjustable leveling.

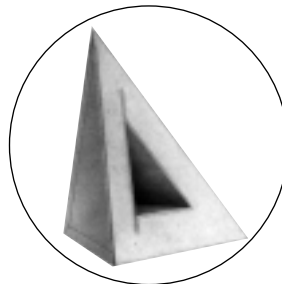

FULLY INSULATED CABINET

Foam insulation is forced between the wall and liner under heat and pressure to form a perfect wall to wall bond thus preserving ice supply for long periods.



Scotsman is proud to announce that we are ISO-9001:2000 Certified



 **Scotsman**[®]

Bin Specifications

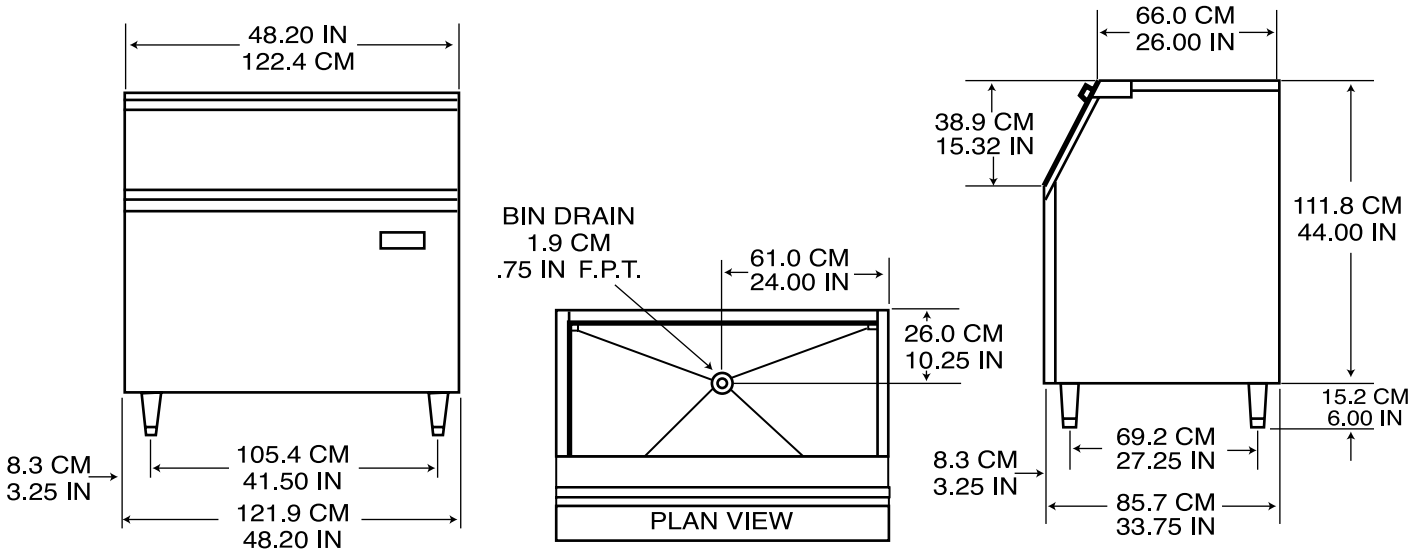

NOTE: Allow 6" minimum space at back for ice machine ventilation and utility connections.

SCOTSMAN MODULAR BIN					Certified & rated in accordance with ARI standard 820-95
Model Number	Dimensions W"xD"xH"	ARI Bin Capacity lbs./kg.	Application Capacity lbs./kg.	Finish*	Ship Weight lbs./kg.
BH900S-C	48.2 x 33.75 x 44	740/336	940/426	SS	185/84

*(SS) Stainless steel cabinet with a polyethylene liner.
 NOTE: Add 6" height for legs.

ACCESSORIES

Model Number	Description	Application	Ship. Wt. lbs./kg.
KBT22	Bin Top	Use with CME256, CME506, CME656, CME806, CME1056, NME1254, FME1504.	11/5
KBT24	Bin Top	Use with NME654, NME954, FME804, FME1204.	14/6
KBT25	Bin Top	Use with (2) NME654, (2) NME950, (2) FME804, (2) FME1204.	5/2
KBT14	Bin Top	Use with NME1854, FME2404.	8/4
KLP6	Heavy-duty leg kit	6" aluminum legs & bracket. Must be used when machines are stacked.	25/11
KLP7	Flanged-feet leg kit	6" black enamel legs with flanged feet.	5/2
KBC9	Caster kit	Raises bin maximum 9.75". Not to be used when machines are stacked.	30/14

Scotsman's ice machines and bins are not designed for outdoor installations. Scotsman remote condensers are designed for outdoor installations.

Machine requires voltage indicated on rating name plate. Failures caused by improper voltage are not considered factory defects. Extended periods of operation at temperatures exceeding limitations constitutes misuse under the terms of Scotsman Manufacturer's Limited Warranty, resulting in a loss of warranty coverage. Specifications and design are subject to change without notice.

Consult Your Local SCOTSMAN Representative At:

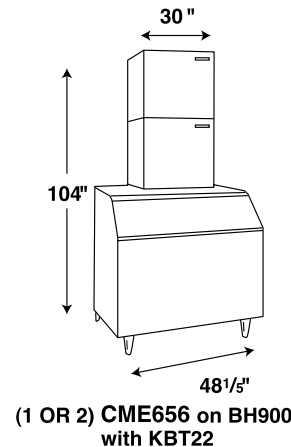
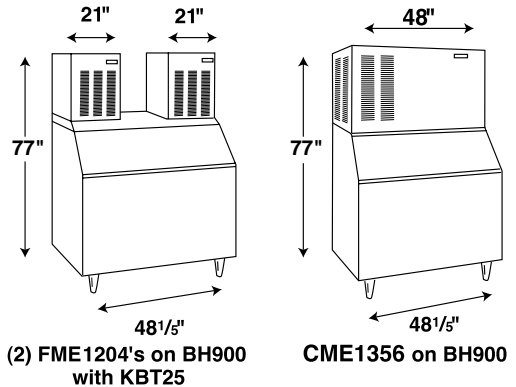

YOU'LL VALUE THE DIFFERENCE™

775 Corporate Woods Parkway • Vernon Hills, IL 60061 • 1-800-SCOTSMAN • (847) 913-9844
 Visit our website at: www.scotsman-ice.com • E-mail: customer.service@scotsman-ice.com

