



Project _____
 AIA # _____ SIS # _____
 Item # _____ Quantity _____ C.S.I. Section 114000

G SERIES

1-Section Hot Food Holding Cabinets Pass-Thru, Solid Door(s)



STANDARD PRODUCT FEATURES

- High Performance, Heating System Operates At 140° to 180°F
- Reliable Microprocessor Control With LED Temperature Display
- Load-Sure™ Guard Prevents Problems From Improper Loading
- Durable All Metal Construction
- Stainless Steel Front & Doors, Anodized Aluminum Sides & Interior
- Full or Half Height Door Models with a Variety of Hinging Configurations
- Long Life EZ-Clean™ Door Gaskets
- Three (3) Plated Shelves Per Section (factory installed)
- 6" High Locking Casters

FIELD INSTALLED ACCESSORIES & OPTIONS

- Trayslides for 18" x 26" Sheet Pans
- Trayslides for 12" x 20" Food Pans
- Trayslides for 14" x 18" Sheet Pans
- Additional Shelves
- Set of (4) 4 1/8" Casters in Lieu of Standard
- 6" High Legs

***Please refer to the G-Series Accessory Kit Guide for precise details. (Form TR35872)**



Models listed to the applicable UL, CSA and NSF standards by an approved NRTL. Consult the factory or unit data plate for additional information.

AVAILABLE CONFIGURATIONS

Model	Control Side Door Style/Hinging	Non Control Side Door Style/Hinging
G14302P	Half Height/Right	Half Height/Right
G14303P	Half Height/Right	Half Height/Left
G14304P	Half Height/Left	Half Height/Left
G14305P	Half Height/Left	Half Height/Right
G14312P	Full Height/Right	Full Height/Right
G14313P	Full Height/Right	Full Height/Left
G14314P	Full Height/Left	Full Height/Left
G14315P	Full Height/Left	Full Height/Right

**-GUARANTEED FOR LIFE CAM-LIFT HINGES
 -GUARANTEED FOR LIFE HORIZONTAL
 WORKFLOW DOOR HANDLES (SOLID DOORS ONLY)**



ENERGY STAR® Listed Commercial Hot Food Holding Cabinet
 For full listing visit energystar.gov

Approved by _____ Date _____ Approved by _____ Date _____

MODELS:

G14302P, G14303P, G14304P, G14305P

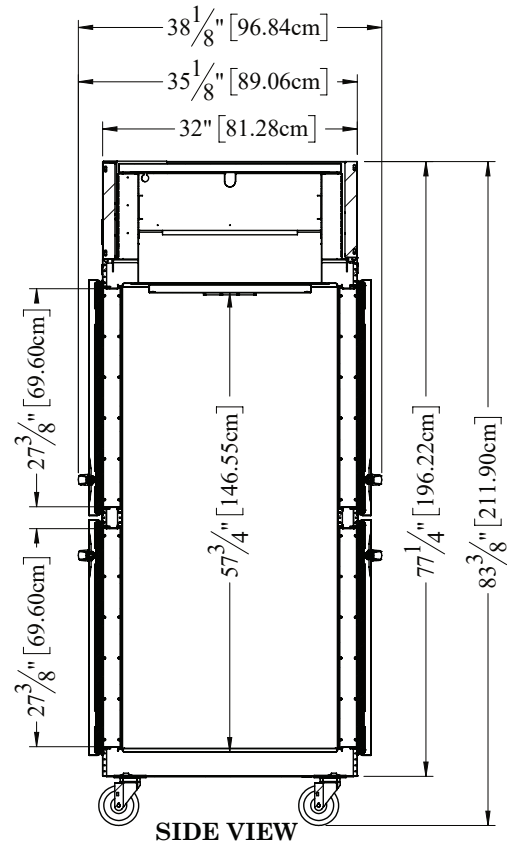
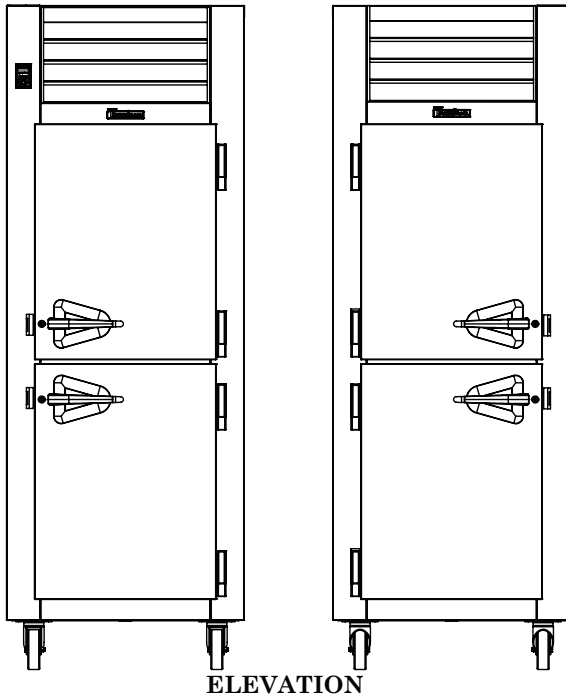
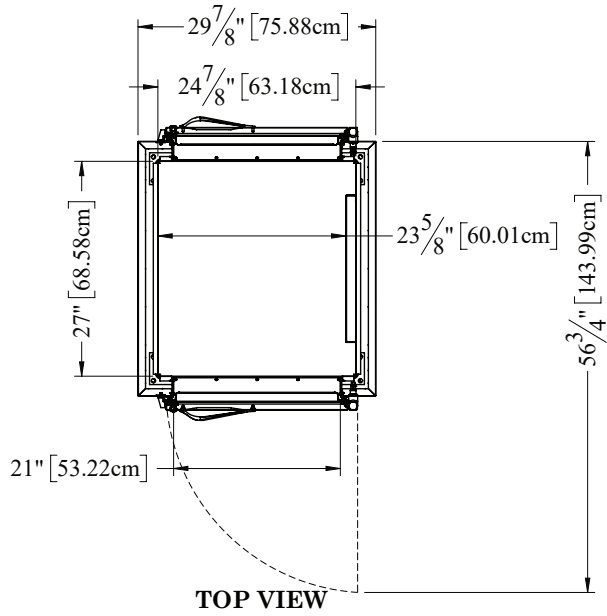

G-SERIES

1-Section Hot Food Holding Cabinets Pass-Thru, Solid Door(s)

MODELS:

G14312P, G14313P, G14314P, G14315P

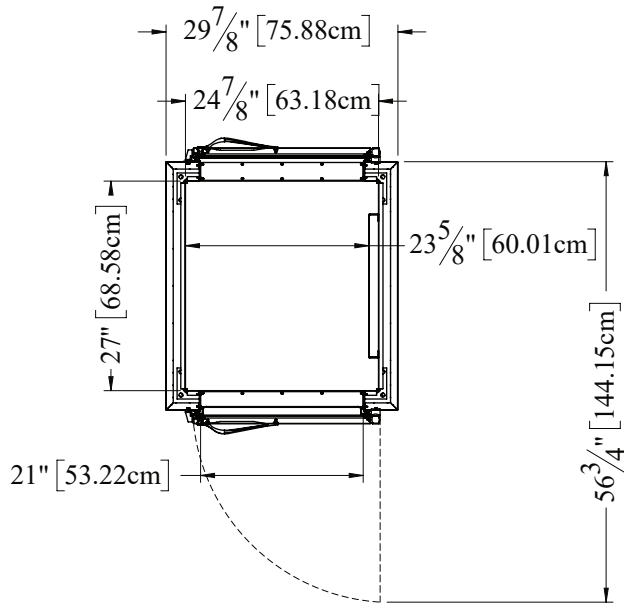

TOP VIEW

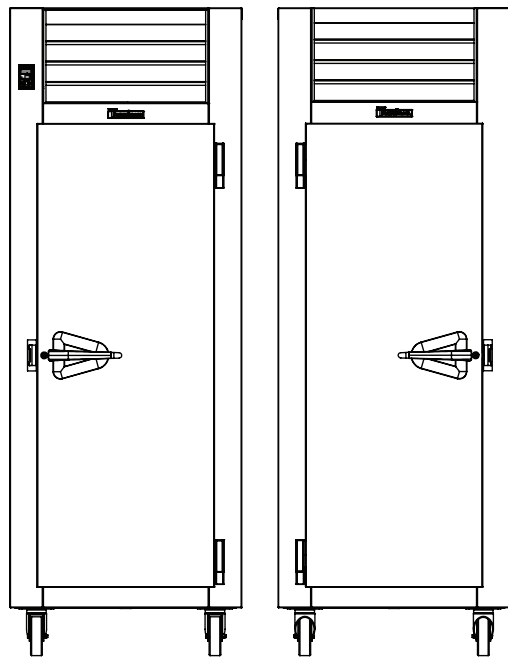

ELEVATION

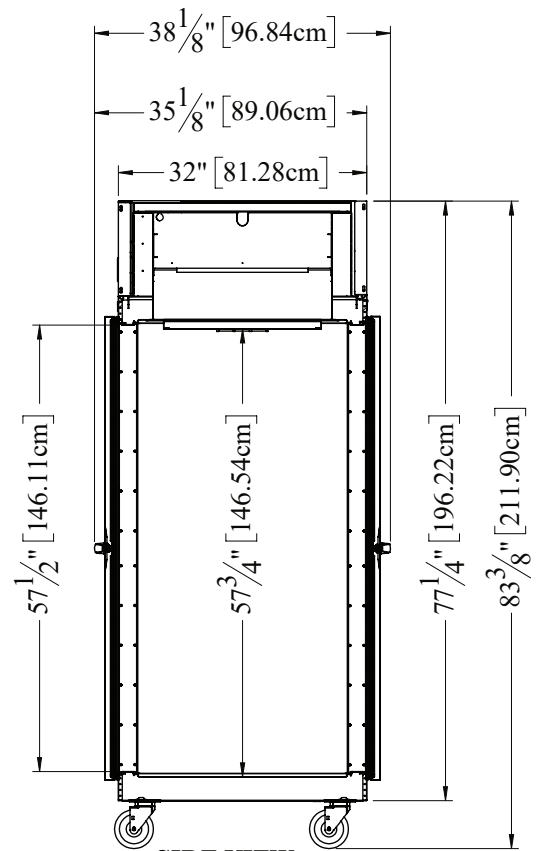

SIDE VIEW



G SERIES

1-Section Hot Food Holding Cabinets Pass-Thru, Solid Door(s)

MODELS:

Half Height Door Models: G14302P, G14303P, G14304P, G14305P

Full Height Door Models: G14312P, G14313P, G14314P, G14315P

EQUIPMENT SPECIFICATIONS

MODELS	G143__P
DIMENSIONAL DATA	
Net Capacity cu. ft.	26.0 (736 l)
L x D x H - Overall in. ¹	29 ⁵ / ₈ (75.9 cm) x 38 ¹ / ₈ (96.8 cm) x 83 ³ / ₈ (211.9 cm)
Depth - over body in.	32 (81.3 cm)
Depth - door open 90° in.	56 ³ / ₄ (144.2 cm)
Clear half-door W x H in.	21 (53.2 cm) x 27 ⁵ / ₈ (69.6 cm)
Clear full-door W x H in.	21 (53.2 cm) x 57 ¹ / ₂ (146.1 cm)
No. Standard Shelves	3
Shelf Area sq. ft. ²	18.8 (1.75 sq m)
ELECTRICAL DATA	
Voltage Plug	208-230/115/60/1 NEMA L-14-20P (attached)
Feed wires with ground	4
Wattage @ 208V	1500
Full Load Amperes	8.3
SHIPPING DATA	
L x D x H Crated in.	48 (122 cm) x 42 (107 cm) x 85 (216 cm)
Volume Crated cu. ft.	99 (2803 l)
Uncrated Crated Weight lbs.	270 (122 kg) 315 (143 kg)

CONSTRUCTION, HARDWARE, INSULATION

Cabinet exterior front, louver assembly and doors are constructed of heavy gauge stainless steel. Cabinet sides (including returns), interior and door liners are constructed of anodized aluminum. The exterior cabinet top, back and bottom are constructed of heavy gauge galvanized steel. A set of four (4) 6" high casters are included. Doors are equipped with a gasket protecting metal door pan, removable plug cylinder locks and guaranteed for life cam-lift, gravity action, self-closing metal, glide hinges with stay open feature at 120 degrees. Hinges include a concealed switch to automatically activate the interior LED lighting. Guaranteed for life, work flow door handles are mounted horizontally over recess in door which limits protrusion from door face into aiseways. Gasket profile and durable long life material simplify cleaning and increase overall gasket life. Both the cabinet and door(s) are insulated with an average of 2" thick high density, non-CFC, foamed in place polyurethane.

HEATING SYSTEM

A low watt density, serpentine style, heater is employed for the generation of electric heat. Low velocity air is forced across its large surface area to efficiently move heat radiating away from these through a down-air distribution duct, where it is then evenly distributed throughout the cabinet, assuring the proper holding environment for hot food product, without drying. A vent, located at the top of the cabinet, is included for positive humidity control. Standard operating temperature range 140° to 180°F.

CONTROL

The easy to use water resistant microprocessor control is supplied standard. It includes a 3-Digit LED Display, and a Fahrenheit or Celsius Temperature Scale Display Capability.

INTERIOR ARRANGEMENTS

Standard interior arrangements include three (3) plated shelves, mounted on pilasters, installed at the factory. Recommended load limit per shelf should not exceed 225 lbs.

DOMESTIC WARRANTY

A six year parts and labor warranty is provided standard.

NOTES:

1. Height shown when mounted on standard 6" high casters.
2. Figure shown reflects the area of standard shelf complement.

OPTIONAL ACCESSORY TRAY SLIDE VERSATILITY CHART						
TRAY SLIDE DRAWINGS						
TRAY SLIDE OFFERING	#1 (1) 18" x26" or (2) 14" x18"	#4 (Rod Type) (1) 18" x26"	Universal (1) 18" x26" or (2) 14" x18" or (2) 12" x20"	#1 EZ-Change (1) 18" x26" or (2) 14" x18"	Universal EZ-Change (1) 18" x26" or (2) 14" x18" or (2) 12" x20"	HD Universal EZ-Change (1) 18" x26" or (2) 14" x18" or (2) 12" x20"
SPACING CAPACITY DOOR SIZE	2" 28 Pairs Full Door & 13 Half 3" 19 Pairs Full Door & 09 Half 4" 14 Pairs Full Door & 07 Half 5" 11 Pairs Full Door & 05 Half	1 1/2" 38 Pairs Full Door (2 Pair) 1 1/2" 18 Pairs Half Door (1 Pair)	4" 14 Pairs Full Door & 06 Half ¹ 4" 14 Pairs Full Door & 07 Half ² 5" 11 Pairs Full Door & 05 Half 6" 09 Pairs Full Door & 04 Half	2" 26 Pairs Full Door & 12 Half 4" 13 Pairs Full Door & 06 Half	2 1/4" 22 Pairs Full Door & 11 Half 4 1/2" 11 Pairs Full Door & 05 Half	4 1/2" 11 Pairs Full Door & 05 Half 9" 05 Pairs Full Door & 02 Half

- Upper Half Height Door¹
- Lower Half Height Door²

CONTINUED PRODUCT DEVELOPMENT MAY NECESSITATE SPECIFICATION CHANGES WITHOUT NOTICE.